

MOFFAT

The Catering Equipment
Company

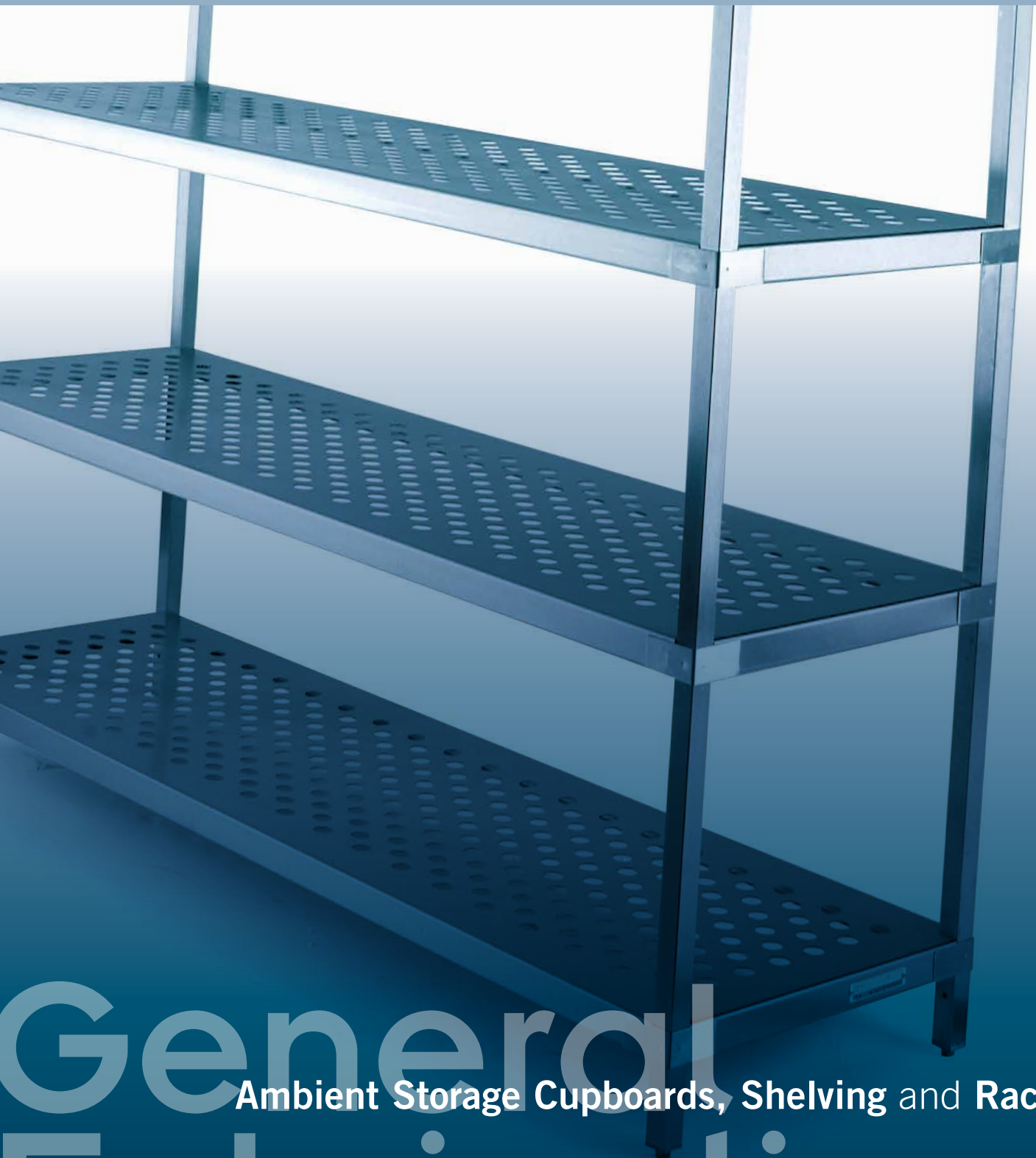

Ambient Storage Cupboards, Shelving and Racking

General
Fabrication

Medium duty wall storage cupboards & medium duty centre storage cupboards



Wall Mounted Cupboards

Models WC9, WC10, WC11, WC12, WC15

These units come complete ready to fix to wall with full area back panel, double skin end panels, sliding doors which lift off easily for cleaning and each cupboard has a base and adjustable centre shelf. Optional hinged doors are available at extra cost on cupboards up to 1200mm long and locks can also be fitted to any units extra cost. All these units are 600mm high.



Medium Duty Wall Storage Cupboard

Models FWC (shown with optional castors)

Tops manufactured from type 304 satin polished stainless steel with 50mm turn down. This unit has a 40mm upstand and folded boxed edge to the rear. The storage cupboard underneath has sliding doors and is fitted with stainless steel legs with adjustable feet or the option of castors. The inside of the units are fitted with bright polished stainless steel for ease of cleaning and have a base and intermediate shelf.



Medium Duty Centre Storage Cupboard

Models FCC (shown with optional castors)

Tops manufactured from type 304 stainless steel with tops turned down to 50mm with a satin polished finish. The storage cupboard underneath has sliding doors and is fitted with stainless steel legs with adjustable feet or the option of castors. The inside of the units are fitted with bright polished stainless steel for ease of cleaning and have a base and intermediate shelf.

COSHH Cupboards

COSHH Cupboards 304 Grade Stainless Steel

Stainless Steel Models
CH94FS3, CH94ES3, CH96FS3, CH96ES3, CH124FS3, CH124ES3, CH126FS3, CH126ES3

430 Grade Stainless Steel

Stainless Steel Models
CH94FS4, CH94ES4, CH96FS4, CH96ES4, CH124FS4, CH124ES4, CH126FS4, CH126ES4

All 900mm long COSHH Cupboards are fitted with hinged doors as standard. Double skin doors and panels, lockable doors and 4 adjustable shelves are also standard.

All 1200mm long COSHH Cupboards are fitted with top hung sliding doors as standard. Double skin doors and panels, lockable doors and 4 adjustable shelves are also standard.

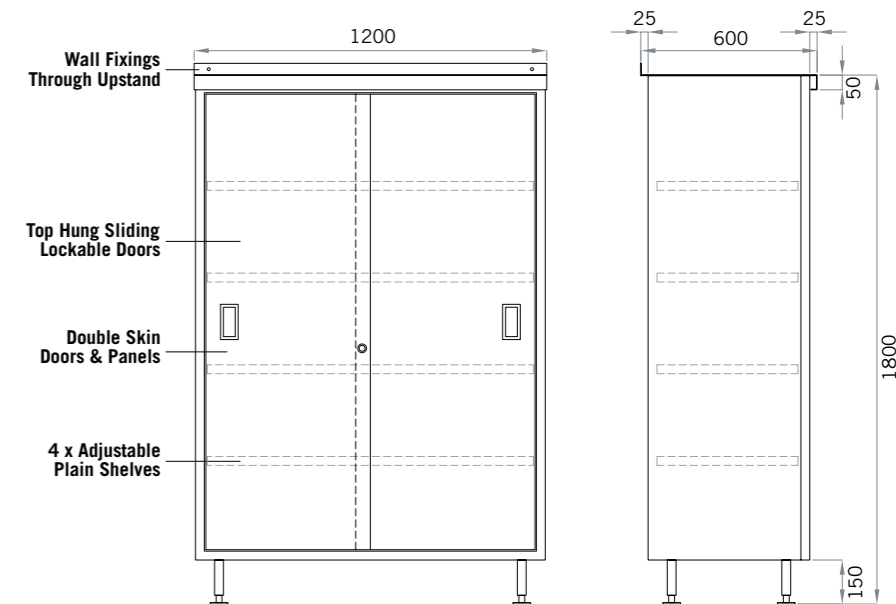
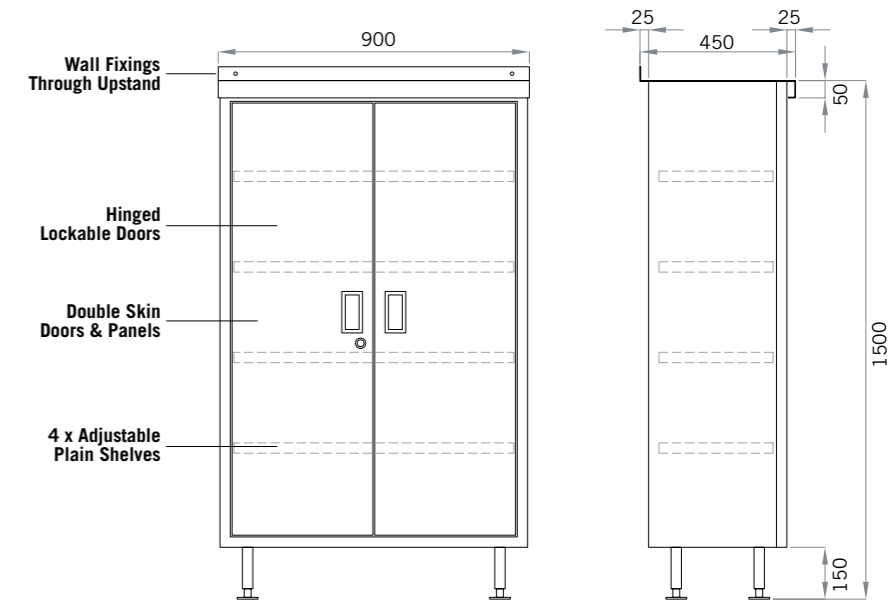

MODEL	WC9	WC10
Weight kg	20	21
Length mm	900	1000
Depth mm	295	295
Height mm	595	595
MODEL	WC11	WC12
Weight kg	22	23
Length mm	1100	1200
Depth mm	295	295
Height mm	595	595
MODEL	WC15	
Weight kg	28	
Length mm	1500	
Depth mm	295	
Height mm	595	

FWC/FCC1265	FWC/FCC1565	FWC/FCC1865	MODEL
40	50	60	Weight kg
1200	1500	1800	Length mm
650	650	650	Depth mm
900	900	900	Height mm
FWC/FCC127	FWC/FCC157	FWC/FCC187	MODEL
43	53	63	Weight kg
1200	1500	1800	Length mm
700	700	700	Depth mm
900	900	900	Height mm

304 Grade Models								MODEL
CH94FS3	CH94ES3	CH96FS3	CH96ES3	CH124FS3	CH124ES3	CH126FS3	CH126ES3	Weight kg
55	58	63	65	75	79	85	87	Length mm
900	900	900	900	1200	1200	1200	1200	Depth mm
450	450	600	600	450	450	600	600	Height mm
1500	1800	1500	1800	1500	1800	1500	1800	
430 Grade Models								MODEL
CH94FS4	CH94ES4	CH96FS4	CH96ES4	CH124FS4	CH124ES4	CH126FS4	CH126ES4	Weight kg
55	58	63	65	75	79	85	87	Length mm
900	900	900	900	1200	1200	1200	1200	Depth mm
450	450	600	600	450	450	600	600	Height mm
1500	1800	1500	1800	1500	1800	1500	1800	

Wall Mounted Shelving



Pot Shelving
Models PS9, PS12, PS15, PS18,

Wall shelving has a weight capacity of 50kg for every 1000mm in length depending on wall fixings.
Usable area: Length x 300mm to wall
25mm diameter bright polished hanging rail under
Gusset size 280mm with a 30mm flange on three sides for wall fixing

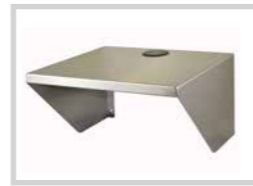

Microwave Shelf
Model MWS1

Standard size 500 x 450mm
other sizes are available on request.

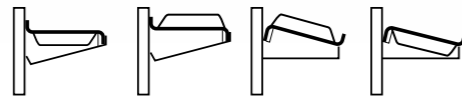

Adjustable Tiered Wall Shelving
Models WS1/6, WS1/9, WS1/12, WS1/15, WS1/18, WS2/6, WS2/9, WS2/12, WS2/15, WS2/18, WS3/6, WS3/9, WS3/12, WS3/15, WS3/18
Single tier=WS1 Two tier=WS2 Three tier=WS3

Moffat wall shelving is manufactured from satin polished stainless steel. Wall rails 800mm long are top-hat shaped and perforated full length. Wall brackets are fully adjustable for height and are reversible giving option of flat or sloping shelves or mix of both. Shelves are 300mm deep and have 25mm turn down to three sides and turn up to one long edge. Four shelf positions possible (see diagram above).



Wall Shelving
Models SWS9, SWS12, SWS15, SWS18, SWS21, SWS24

Single wall shelf 300mm deep with turn down to front and ends and turn up to rear. Corners of shelf and bracket interlock allowing the shelf to be easily removed for cleaning. Each shelf comes complete with wall brackets, two for lengths up to 1500mm and three for lengths up to 2400mm.

All wall shelving has a weight capacity of 50kg for every 1000mm in length depending on wall fixings.

Shelving System/Racking

Designed for use in cold or dry stores, these extendable units will suit all types of application including restaurants, hospitals, warehouses, butcheries and bakeries.

Uprights are made from 30mm square section stainless steel with adjustable feet to compensate for uneven surfaces. Shelves are manufactured in stainless steel with a 50mm downturn and 15mm return all round in a satin smooth polish finish and are available in plain or perforated styles. Our unique 'Versiclamp' system holds the shelves securely in place but allows for infinite adjustment to the distance between shelves. These shelving systems are available in 1500mm or 1800mm high units. These units can be supplied fully assembled or as a flat pack budget option with tools and instructions.

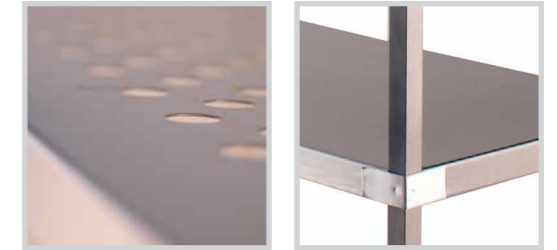

6S15PL



6S15PF

MODEL	WS1/6	WS1/9	WS1/12	WS1/15	WS1/18	PS9	PS18
Weight kg	-	-	-	-	-	-	-
Length mm	600	900	1200	1500	1800	900	1800
Depth mm	300	300	300	300	300	300	300
MODEL	WS2/6	WS2/9	WS2/12	WS2/15	WS2/18	PS12	
Weight kg	-	-	-	-	-	-	
Length mm	600	900	1200	1500	1800	1200	
Depth mm	300	300	300	300	300	300	
MODEL	WS3/6	WS3/9	WS3/12	WS3/15	WS3/18	PS15	
Weight kg	-	-	-	-	-	-	
Length mm	600	900	1200	1500	1800	1500	
Depth mm	300	300	300	300	300	300	

See price list for detailed specification

SWS9	SWS18	MWS1
-	-	-
900	1800	500
300	300	450
SWS12	SWS21	
-	-	
1200	2100	
300	300	
SWS15	SWS24	
-	-	
1500	2400	
300	300	

6S6PL 6S6PF	6S9PL 6S9PF	6S12PL 6S12PF	6S15PL 6S15PF	6S18PL 6S18PF	6S6PLSS 6S6PFSS	6S9PLSS 6S9PFSS	6S12PLSS 6S12PFSS	6S15PLSS 6S15PFSS	6S18PLSS 6S18PFSS
600	900	1200	1500	1800	600	900	1200	1500	1800
520	520	520	520	520	520	520	520	520	520
1500	1500	1500	1500	1500	1500	1500	1500	1500	1500
430	430	430	430	430	304	304	304	304	304
250	225	200	150	125	250	225	200	150	125
6S6PLH 6S6PFH	6S9PLH 6S9PFH	6S12PLH 6S12PFH	6S15PLH 6S15PFH	6S18PLH 6S18PFH	6S6PLSSH 6S6PFSSH	6S9PLSSH 6S9PFSSH	6S12PLSSH 6S12PFSSH	6S15PLSSH 6S15PFSSH	6S18PLSSH 6S18PFSSH
600	900	1200	1500	1800	600	900	1200	1500	1800
520	520	520	520	520	520	520	520	520	520
1800	1800	1800	1800	1800	1800	1800	1800	1800	1800
430	430	430	430	430	304	304	304	304	304
250	225	200	150	125	250	225	200	150	125

PF = 430 stainless steel perforated shelf
PL = 430 stainless steel shelf

PLSS = 304 stainless steel shelf
PFSS = 304 stainless steel perforated shelf

Codes ending in H denote 1800mm high racking

MODEL
Length mm
Depth mm
Height mm
Stainless steel type
Capacity per shelf kg
MODEL
Length mm
Depth mm
Height mm
Stainless steel type
Capacity per shelf kg

Racking



CAN144

Can Rack
Models CAN48, CAN96, CAN144



Mobile Can Rack
CAN 54M

These units not only provide an excellent storage solution but are also easy to use, simply load cans at one end and they roll to the front meaning automatic stock rotation. The unit can accommodate any size of can up to A10 and the can runners are removable for easy cleaning.

Vegetable Rack
Models VEG1, VEG2, VEG3

Three tier veg racks provide good air circulation to stored vegetables. Constructed from galvanised mild steel sheet, supplied with soil spillage drawer and removable wire mesh shelves.



VEG1



PSS12

Sack Stand
Models PSS12, PSS15, PSS18

Manufactured from square section stainless steel in satin polish finish with adjustable feet for uneven surfaces.

Mobile Racking

Trolleys are available for a variety of applications and conditions. Manufactured from stainless steel with welded joints. 125mm castors, two of which are braked.

Zee Rack
Model ZMT

Mobile racks designed to nest into each other when empty to enable five racks to occupy the area normally occupied by two. Designed to take gastronorm containers or gastronorm size laminate trays. Ideal for receiving, transporting, preparing, storing, serving or delivering food. Uprights and diagonal ties in 30mm square section steel (type 304) welded together to form 'Z' shaped framework. Fitted with 19 pairs of anti tip channel slides manufactured in stainless steel (type 304) riveted to uprights at a spacing of 70mm. When using Gastronorm size containers a total of 18 pairs of slides are used as the bottom slide cannot be used. When using Gastronorm size laminate trays, a total of 18 pairs of slides are used as the top slide cannot be used. Fitted with four 125mm diameter swivel castors, two with brakes. Revolving buffers for protection.



Standard Mobile Rack
Model SMT

Designed for gastronorm containers or gastronorm size laminate trays. Ideal for receiving, transporting, preparing, storing, serving or delivering food.



MODEL	CAN54M	CAN48	CAN96	CAN144	PSS12	PSS15	PSS18	VEG1	VEG2	VEG3	ZMT	SMT	MODEL
Weight kg	42	40	70	86	10	14	18	37	72	109	28	26	Weight kg
Length mm	665	252	475	665	1200	1500	1800	470	920	1400	680	660	Length mm
Depth mm	908	908	908	908	600	600	600	620	620	620	750	672	Depth mm
Height mm	900	2000	2000	2000	150	150	150	1470	1470	1470	1705	1600	Height mm
Capacity A10 cans	54	48	96	144							-	-	No. of Shelves
											36	36	Capacity 1/1 Gastronorm containers



The Catering Equipment
Company



Our Green Thinking logo highlights innovation in our manufacturing which makes our products environmentally conscious through energy savings, sustainability and efficiency in production



Regeneration
& Keep Hot



General
Fabrication

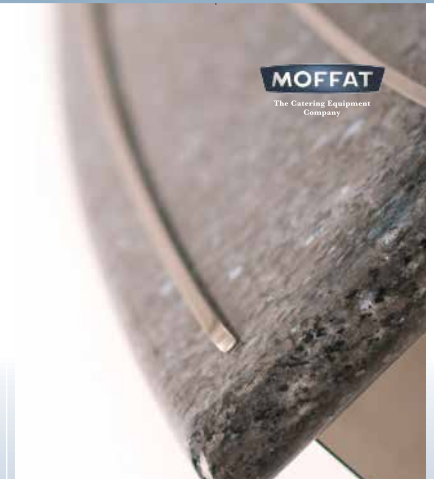

Countering

E & R Moffat Ltd.
Bonnybridge
FK4 2BS
Scotland

T +44 (0) 1324 812272
F +44 (0) 1324 814107
E sales@ermoffat.co.uk
www.ermoffat.co.uk